

## A teaching model for truss structures

This article has been downloaded from IOPscience. Please scroll down to see the full text article.

2012 Eur. J. Phys. 33 1179

(<http://iopscience.iop.org/0143-0807/33/5/1179>)

View [the table of contents for this issue](#), or go to the [journal homepage](#) for more

Download details:

IP Address: 193.205.203.3

The article was downloaded on 06/07/2012 at 13:50

Please note that [terms and conditions apply](#).

# A teaching model for truss structures

**Davide Bigoni<sup>1</sup>, Francesco Dal Corso, Diego Misseroni and Mirko Tommasini**

Department of Mechanical and Structural Engineering, University of Trento, via Mesiano 77, I-38123 Trento, Italy

E-mail: [bigoni@unitn.it](mailto:bigoni@unitn.it), [francesco.dalcorso@unitn.it](mailto:francesco.dalcorso@unitn.it) and [diego.misseroni@unitn.it](mailto:diego.misseroni@unitn.it)

Received 24 March 2012, in final form 28 May 2012

Published 5 July 2012

Online at [stacks.iop.org/EJP/33/1179](http://stacks.iop.org/EJP/33/1179)

## Abstract

A classroom demonstration model has been designed, machined and successfully tested in different learning environments to facilitate understanding of the mechanics of truss structures, in which struts are subject to purely axial load and deformation. Gaining confidence with these structures is crucial for the development of lattice models, which occur in many fields of physics and engineering.

(Some figures may appear in colour only in the online journal)

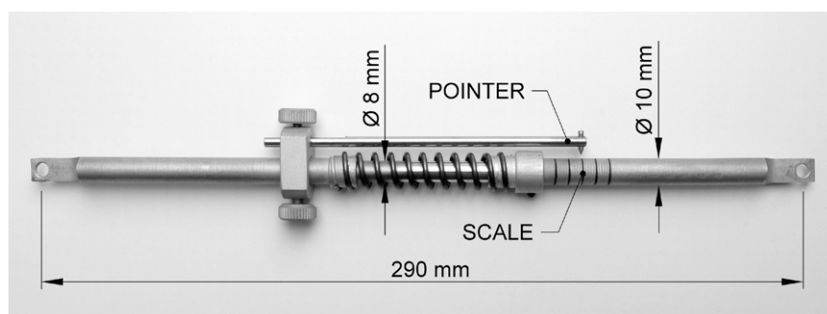
## 1. Introduction

The way in which a *truss structure* can be seen to have all elements subject to purely axial force is complex and the way it deforms under loading is definitely not intuitive, even for undergraduate students of mathematics, physics, and engineering. Truss structures are *optimal*, ubiquitous and so important from many perspectives that they deserve special attention. Moreover truss structures are used in many traditional technologies, for example, bridges, electricity pylons, cranes, airplanes, cars, motorcycles and innovative applications such as nanotrusses [8]) and are crucial for the understanding of several biological structures, for instance, vertebrate skeletons [4] and protein materials [1]) and as conceptual models in physics (e.g. crystal lattices). Our aim was to develop a teaching model to enhance students' ability to visualize the deformation of such lattice structures, which is the primary key to 'catch the concept'<sup>2</sup>.

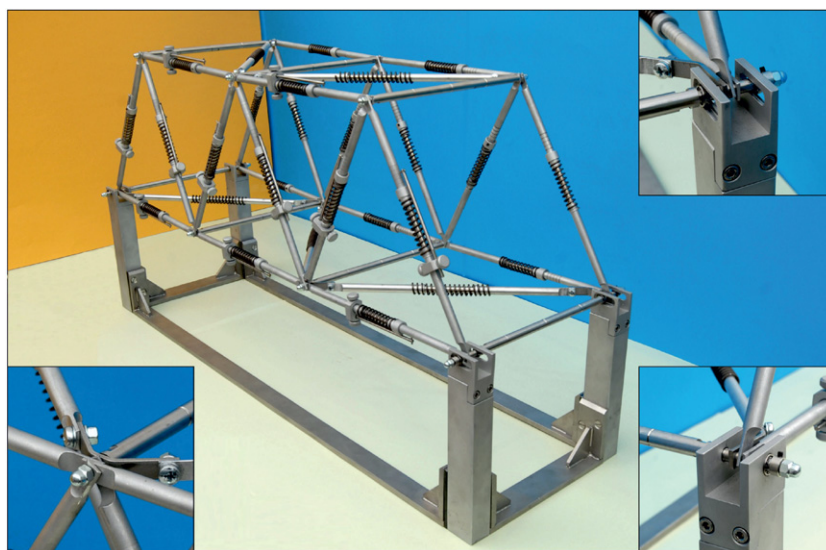
Models of elastic truss structures have previously been developed to both stimulate students' interest and to form an experimental outlook in undergraduate teaching [2, 5–7].

<sup>1</sup> Author to whom any correspondence should be addressed.

<sup>2</sup> Cross and Morgan [3] wrote: 'The ability of a designer of continuous structures is measured chiefly by his ability to visualize the deformation of the structure under load. If he cannot form a rough picture of these deformations when he begins the analysis he will probably analyse the structure in some very awkward and difficult way; if he cannot picture these deformations after he has made the analysis, he doesn't know what he is talking about. The more or less gentle reader may find the constant repetition of this theme monotonous, but it is the deliberate conclusion of the authors that the most important aspect of the subject is the simple picture of structural deformation.' We completely agree with this statement, which has become even more evident nowadays in that numerical simulations often obscure physical intuition.



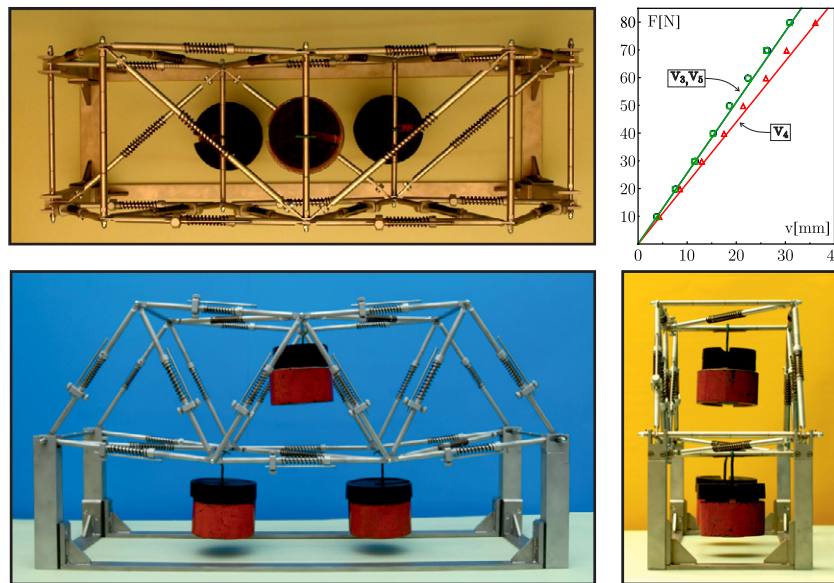
**Figure 1.** The spring snubber element used for the truss structure shown in figure 2. Note the movable pointer to measure elongation/shortening.



**Figure 2.** View of the (unloaded) spatial Warren truss model, with details (an internal node on the left, two external nodes on the right: a roller and a hinge).

However, the models developed by Pippard [7] are simple three-element planar systems, while Hilson [6] provides only qualitative experiments, and Godden [5] focuses on the buckling of compressed elements. Moreover, in the models proposed by Charlton [2], the struts are ‘Z-shaped’ members deforming under flexure (see his figure 17), and do not directly show elongation or shortening, so that the mechanical behaviour is too complex and cannot be followed by an untrained audience. Therefore, we have developed spring-strut elements, capable of sustaining large deformation (figure 1), and connected these elements into various structural forms through bolted junctions. (One geometry is only reported here for brevity, namely, a Warren truss design—an assembly of bars arrayed in an alternately inverted equilateral triangle geometry—figure 2.)

The first prototype (not reported here for brevity) that we developed was planar and, though light, simple and very accurate in reproducing deformation, did not illustrate the problem of the need for braces to avoid out-of-plane instability. Therefore, we developed the fully spatial



**Figure 3.** Frontal (lower part, left), lateral (lower part, right) and top (upper part, left) view for the symmetric load combination. A comparison between theoretical predictions and experimental data is also included in terms of applied load  $F$  versus the mean value of measured nodal vertical displacements  $v$  (upper part, right).

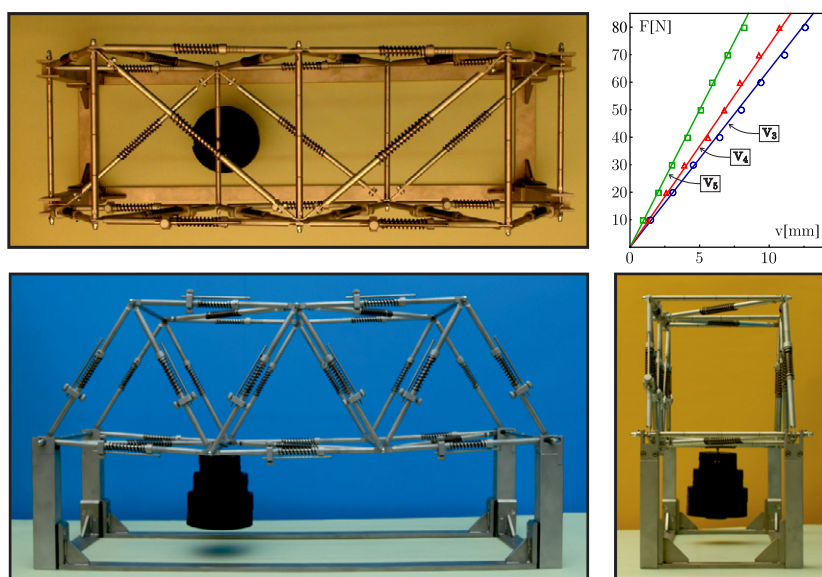
model shown in figure 2, which can effectively demonstrate the importance of cross bracing; see also the electronic supporting material at <http://ssmg.unitn.it>. This model is addressed to the simplest geometry, namely a Warren structure, often employed in bridges (so that it can be used to explain the mechanics of a truss structure), though it is fully representative of the behaviour of elastic lattice models.

The two teaching models have been employed regularly for ten years of undergraduate classes on the strength of materials (at the University of Trento) and have been used for: (i) two university orientation courses organized by the ‘Scuola Normale Superiore’ of Pisa, (ii) public demonstrations (for instance, at the so-called ‘researchers’ nights’ in 2010 and 2011) and (iii) presentations given to elementary schools. These models have been proved to exemplify the way a truss structure is designed and deforms, and have been used in undergraduate classes to experimentally assess the validity of structural modelling via linear elasticity.

## 2. The design and performance of the truss model

We started designing and constructing a simple pin-jointed<sup>3</sup> Warren planar truss structure (namely, one wall of the structure considered in the following—figure 2—and not reported here for brevity), in which the straight members have been constructed with spring-strut elements. The model has been used: (i) *qualitatively* to show the ‘global’ behaviour of the structure and to explain the way in which all elements are primarily subject to axial tension or compression, and (ii) *quantitatively* (in undergraduate classes), by calculating the ratio between two or more rods’ elongation (or node displacements) and measuring this ratio on the model.

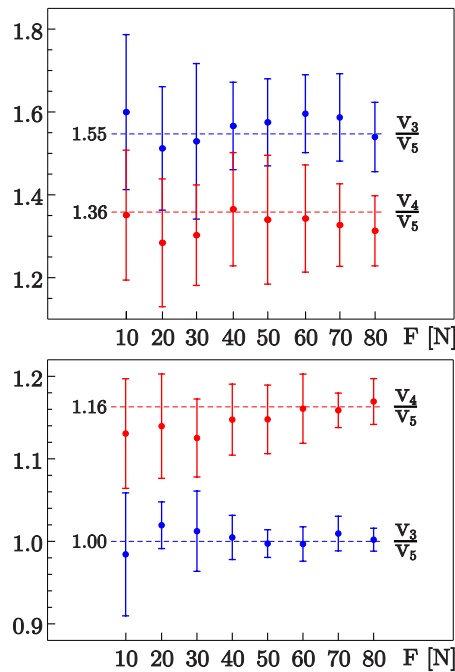
<sup>3</sup> The term ‘pin-jointed’ means that the connection between elements leaves the relative rotation unconstrained.



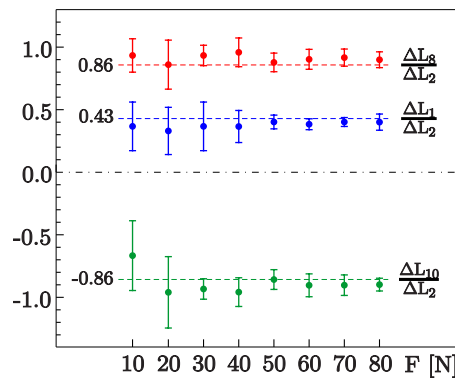
**Figure 4.** As for figure 3, except that the load is asymmetric.

**Table 1.** Measurements on the teaching model loaded symmetrically (figure 3) taken by five different students.

Load F[N]	Node	Measured vertical displacement $v_i$ (mm)					Mean value $\bar{v}_i$ (mm)	Standard deviation $\sigma$ (mm)	Theoretical value $v_i$ (mm)
		St1	St2	St3	St4	St5			
10	3	3.80	4.25	4.35	3.25	3.30	3.79	0.46	3.91
	4	4.30	4.50	4.85	4.25	3.80	4.34	0.34	4.55
	5	3.85	3.90	4.20	3.50	3.75	3.84	0.23	3.91
20	3	8.00	7.85	7.60	7.45	7.35	7.65	0.24	7.82
	4	8.25	8.85	8.25	8.70	8.65	8.54	0.25	9.10
	5	8.00	7.60	7.25	7.65	7.05	7.51	0.33	7.82
30	3	13.10	11.10	11.80	11.45	10.85	11.66	0.79	11.74
	4	14.10	12.75	11.70	13.40	12.85	12.96	0.79	13.65
	5	12.00	11.25	11.30	11.70	11.30	11.51	0.29	11.74
40	3	15.50	14.45	15.95	14.80	15.90	15.32	0.60	15.65
	4	18.10	16.60	16.25	18.35	18.20	17.50	0.89	18.20
	5	15.70	14.40	15.15	15.20	15.80	15.25	0.50	15.65
50	3	19.70	18.00	18.85	17.70	18.80	18.61	0.70	19.56
	4	22.15	20.60	20.15	21.95	22.20	21.41	0.86	22.75
	5	19.45	17.80	18.70	18.20	19.15	18.66	0.60	19.56
60	3	23.30	21.90	23.00	21.90	21.70	22.36	0.66	23.47
	4	26.45	25.20	24.80	26.80	26.90	26.03	0.86	27.30
	5	22.65	21.95	22.80	22.50	22.25	22.43	0.30	23.47
70	3	27.45	25.90	27.25	25.60	25.55	26.35	0.83	27.38
	4	30.80	29.90	29.55	30.10	30.85	30.24	0.51	31.85
	5	26.85	26.00	26.10	25.65	25.90	26.10	0.40	27.38
80	3	30.35	30.60	31.40	31.90	30.45	30.94	0.61	31.29
	4	37.00	35.10	34.85	36.75	36.85	36.11	0.93	36.40
	5	30.75	30.05	31.05	31.60	30.95	30.88	0.50	31.29

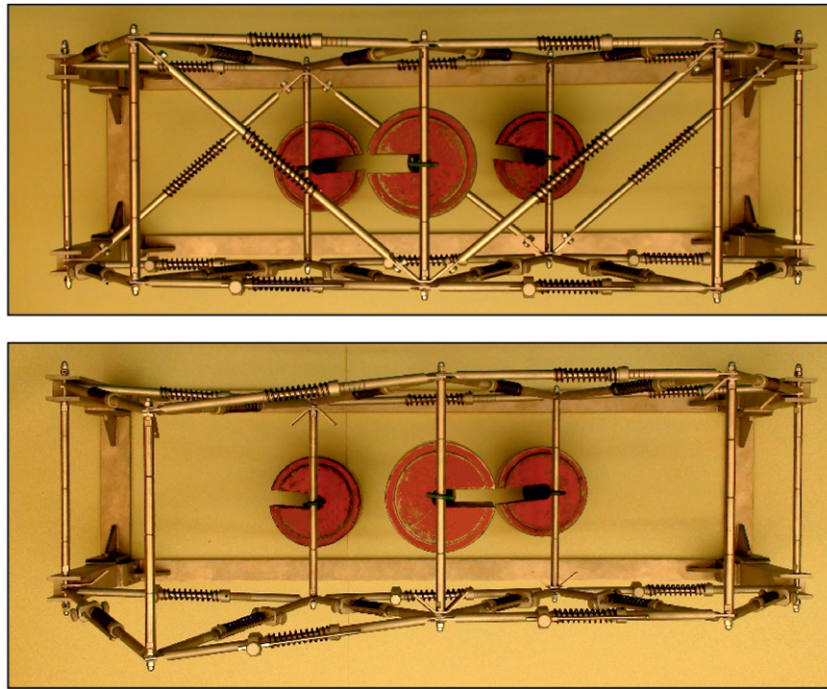


**Figure 5.** Ratios of mean values of the measured vertical displacement (dots) together with relative standard deviation (error bar) and theoretical value (dashed line) for different values of loading for symmetric (upper part) and asymmetric (lower part) conditions.



**Figure 6.** Ratios of mean values of elongation bars (dots) together with relative standard deviation (error bar) and theoretical value (dashed line) for different values of loading for asymmetric conditions.

Classroom presentations of the model have revealed that, although excellent for the above-listed purposes, it did not illustrate the out-of-plane instability of the structure and the consequent need of a cross bracing to the student. Therefore, we designed the spring snubber shown in figure 1, where a movable pointer allows for the measurement of the elongation/shortening of the element, and constructed a sort of ‘Warren truss bridge’ configuration, externally constrained by a hinge and a roller, as shown in figure 2. The snubbers have been machined from aluminium 2117 tubes and the springs have been designed using the well-known formula for helical springs of round wire (see equation (5.3) of [9]) and



**Figure 7.** The effect of cross bracing: top view of the structure with bracing (upper part) and without bracing (lower part). A huge out-of-plane movement occurs (and is visible) when the bracing is removed.

produced with (2 mm diameter) music wire ASTM A228. The external hinge and roller have been constructed with eight roller bearings (SKF-618/5) and the whole structure has been mounted on an AISI 304 stainless steel frame.

The finished model can be used to provide confirmatory experiments in undergraduate classes. In particular, they can be loaded with dead loads and the elongation or shortening of the bars can be measured on the structure by visual inspection employing the pointers. Two load systems, one symmetric and the other asymmetric, are shown in figures 3 and 4. In addition to the elongation of the bars, displacement of the nodes can be measured with a mechanical comparator. The measurements of the bar elongations can be normalized mathematically by one reference elongation and then compared with the predicted ratios between the forces inside the bars, which can be calculated on the blackboard and do not require any stiffness measurement. The model elicits a good comparison between theoretical predictions and experimental values, which is crucial in stimulating students' interest and facilitating their understanding of the capabilities and limits of mechanical modelling, as highlighted, among others, by Pippard [7].

Measurements of vertical displacements at the central node of the upper chord, labelled 4, and the two central nodes of the lower chord, labelled 3 (left) and 5 (right) for different loadings are reported in tables 1 (symmetric loading as in figure 3) and 2 (asymmetric loading as in figure 4), as taken by five different students (labelled 'St' in the tables).

Ratios of mean value of the measured (by five students) and vertical displacements (presented with the standard deviation as an error bar) are compared to the corresponding theoretical values in figure 5 for symmetric (upper part) and asymmetric (lower part) loadings. Mean values of the ratios of bars' elongation are shown in figure 6 for asymmetric loading.

**Table 2.** Measures on the teaching model loaded asymmetrically (figure 4) taken by different students.

Load F[N]	Node	Measured vertical displacement $v_i$ (mm)					Mean value $\bar{v}_i$ (mm)	Standard deviation $\sigma$ (mm)	Theoretical value $v_i$ (mm)
		St1	St2	St3	St4	St5			
10	3	1.85	1.50	1.40	1.35	1.30	1.48	0.20	1.55
	4	1.50	1.25	1.05	1.30	1.15	1.25	0.15	1.36
	5	1.20	0.90	0.85	1.05	0.70	0.94	0.17	1.00
20	3	2.95	3.30	2.75	3.65	2.75	3.08	0.35	3.10
	4	2.75	2.35	2.45	2.80	2.65	2.6	0.17	2.72
	5	1.95	1.90	2.15	2.50	1.75	2.05	0.26	2.00
30	3	4.65	4.65	4.60	4.50	4.35	4.55	0.11	4.65
	4	3.85	4.15	3.45	4.30	3.75	3.90	0.30	4.08
	5	3.30	2.75	2.60	3.60	2.85	3.02	0.37	3.01
40	3	6.10	6.40	6.15	7.40	6.20	6.45	0.49	6.20
	4	5.25	5.80	5.55	6.05	5.35	5.60	0.29	5.44
	5	4.25	3.70	3.75	4.95	4.05	4.14	0.45	4.01
50	3	9.15	7.40	7.40	8.60	7.45	8.00	0.74	7.75
	4	6.20	7.60	6.70	7.10	6.25	6.77	0.53	6.80
	5	5.20	4.70	4.90	5.95	4.70	5.09	0.47	5.01
60	3	9.95	9.20	9.60	10.05	8.25	9.41	0.65	9.30
	4	7.45	8.50	7.85	8.30	7.35	7.89	0.45	8.16
	5	6.15	5.40	5.70	6.70	5.60	5.91	0.47	6.01
70	3	12.40	10.55	11.25	11.55	10.05	11.11	0.88	10.85
	4	9.10	9.20	9.30	9.75	8.95	9.26	0.27	9.52
	5	7.50	6.15	6.85	7.85	6.75	7.02	0.60	7.01
80	3	12.90	11.65	12.50	13.65	12.25	12.59	0.67	12.40
	4	10.00	10.60	10.60	11.55	10.90	10.73	0.50	10.88
	5	7.90	7.20	8.00	9.35	8.60	8.21	0.72	8.01

The experimental values reported in tables 1–2 and in figures 5–6 agree with the predictions from linear elastic theory and this agreement becomes closer at higher loads, where friction at the nodal hinges plays a minor role. Therefore, the constructed teaching model not only provides a qualitative explanation of the mechanics of truss structures, but also a quantitative experimental in-class proof of the validity of the theoretical predictions.

Finally, the truss model can also be effectively employed to explain the importance of cross bracing. Indeed these braces can be easily removed, so that loading of the unbraced model reveals an unstable out-of-plane movement, as illustrated in figure 7.

### 3. Conclusions

A simple physical model has been shown to effectively facilitate the understanding of the mechanical behaviour of truss structures. These are elementary structural forms crucial to the understanding of several conceptual models employed in micro- and nano-technologies, for example, crystal lattices and ultralight nanomaterials, and also in biology, for instance, protein materials.

### Acknowledgments

Financial support from Italian Prin 2009 (prot. 2009XWLFKW-002) is gratefully acknowledged.



## References

- [1] Buehler M J and Yung Y C 2009 Deformation and failure of protein materials in physiologically extreme conditions and disease *Nature Mater.* **8** 175–88
- [2] Charlton T M 1966 *Model Analysis of Plane Structures* (Oxford: Pergamon)
- [3] Cross H and Morgan N D 1932 *Continuous Frames of Reinforced Concrete* (New York: Wiley)
- [4] D'Arcy Thompson W 1917 *On Growth and Form* (Cambridge: Cambridge University Press)
- [5] Godden W G 1962 *Demonstration models for teaching structural mechanics (Engineering Experiment Station Circular no. 78)* (Champaign, IL: University of Illinois Press)
- [6] Hilson B 1972 *Basic Structural Behaviour via Models* (New York: Wiley)
- [7] Pippard A J S 1947 *The Experimental Study of Structures* (London: Edward Arnold & Co)
- [8] Schaedler T A, Jacobsen A J, Torrents A, Sorensen A E, Lian J, Greer J R, Valdevit L and Carter W B 2011 Ultralight metallic microlattices *Science* **334** 962–5
- [9] Wahl A M 1963 *Mechanical Springs* (New York: McGraw-Hill)